

Task Switching – Managing Workload within Digital AFV Systems

Trevor Dobbins, Ryan Meeks, Dan Evans, Stuart Howe, Stephen Barrett

RBSL, United Kingdom

SUMMARY

The Armoured Fighting Vehicle Commander's role is characterised by having multiple mission critical tasks. They are required to rapidly redirect their attention at short notice as events change. This paper describes how this task-switching is modelled and analysed, within the system model, to manage workload and develop/deliver a useable system

KEYWORDS

Workload, task analysis, task switching, system design, system model

Introduction

Within the defence domain, Armoured Fighting Vehicle (AFV) operations place great physical and cognitive demands on the vehicle crews, including the potential to overload both the individuals and team. Workload and its assessment has been a topic of debate for many years, but it is typically assessed on existing or prototype HMI/HCI designs. The design and development of new systems (e.g. including transitioning from analogue to digital systems), prior to building a prototype interface, provides a challenge where an essential requirement is to minimise / optimise workload. Therefore, a practical and efficient design methodology was required to develop a system within a challenging timeframe.

Designing for Minimising / Optimising Workload

Predicting workload is not easy, analysis techniques such as VACP (Visual, Auditory, Cognitive, and Psychomotor) have been used, but these can be of little use in the design of the required system. AFV HMI and HCI designs are based on defined standards; Generic Vehicle Architecture (GVA) HMI and Human Factors Integration (DEFSTANs 23-09 Pt2 and 00-251), and therefore the user interface isn't a blank sheet of paper, rather 'templates' provide the starting point and required system Use Case (UC) functionalities embodied. At RBSL the Task Analysis is based on the System Model (SysML) – the System's *Single Source of Truth* – and its UCs (Dobbins, *et al.* (2021). This is based on the described Battlefield Days (BFDs) and their scenarios. The UCs (Tasks) deliver the detail of how the human / machine system will deliver the system requirements and operational capability.

Task Sequences and Switching

To complete a BFD/scenario, the system (i.e. the crew and platform) completes the required UCs, that are primarily undertaken sequentially, and in some cases concurrently. It is recognised that AFV crews, and particularly Commanders (CMDRs) have a vast range of tasks to undertake. Some aspects being traditionally described as multi-tasking to deliver the required operational effect. The CMDRs role is characterised by workload peaks of unexpected and potentially time and mission

critical events, requiring a rapid redirection of their attention. Rather than multi-tasking, a better description of how the CMDR completes an operation is ‘task switching’, as described by Hutton, Nixon, and Turner (2019). This ability to switch tasks / attention in reaction to unexpected events is critical. Therefore, it is not simply a matter of improving usability, but also improving survivability and safety. As the CMDR is typically completing a ‘linear sequence’ of UCs, they will be required to *switch* to a different UC, e.g. switching from a surveillance task to reacting to a warning. Figure 1 provides an illustration of sequential UCs and task switching to a different UC.

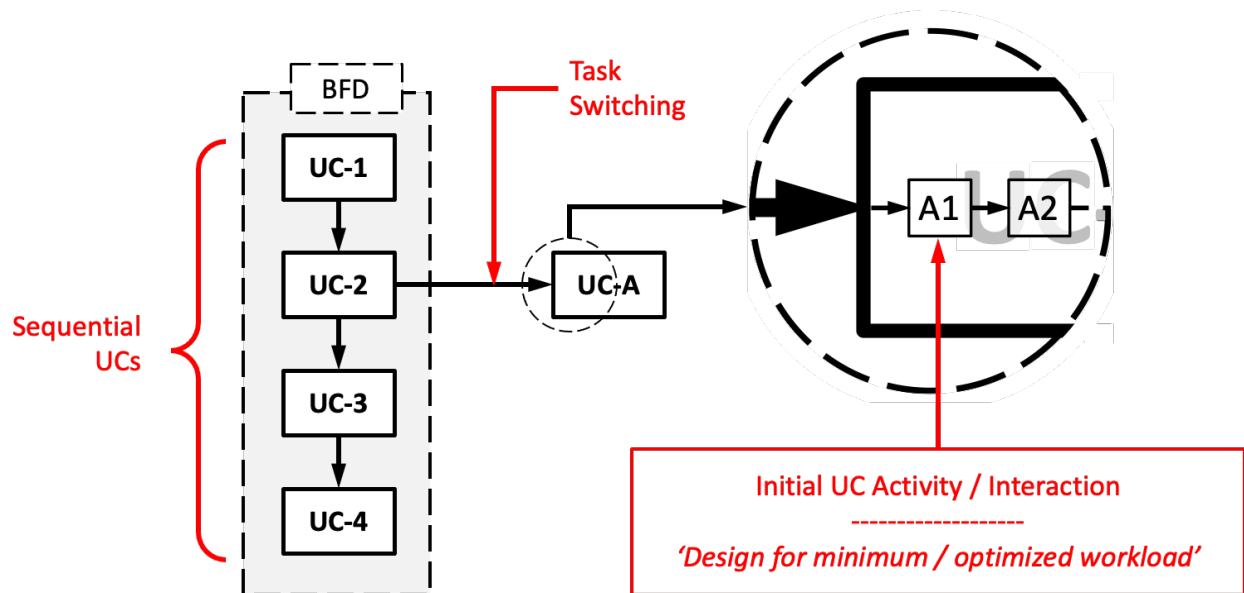

Figure 1: Example of Sequential Use Cases, Task Switching and Designing to Minimise Workload

Designing to Minimise Workload

Using the SysML based Task Analysis, the UCs were evaluated to understand how BFDs/scenarios are completed by the sequential completion of UCs. In addition to these sequences, a group of ‘workload initiator UCs’ were identified with the end-user. This group of UCs are where the CMDR ‘task-switches’ from the linear sequence to a workload initiator UC. As part of the design process, each SysML UC is initially examined and developed to minimise the workload required to undertake it, this includes any User Interfaces (Human Machine Interfaces and Human Computer Interfaces), an example being the HCI developed using wireframing techniques. To minimise the potential increase in workload that a task-switch could initiate, each ‘workload initiator UCs’ was examined, and reviewed by the end-user to ensure the UI actions required to initiate the UC was simple and intuitive.

End-User Evaluation

A primary BFD / scenario was evaluated by a small number of end-user CMDRs, undertaking a ‘cognitive walk through’ where the UCs were examined in detail, along with the HMI (e.g. 3D printed control panels) and HCI (wireframes) designs. Feedback from the CMDRs were used to confirm and/or modify the UCs, HMI, HCI designs prior to prototypes being built for more comprehensive and objective assessment.

Summary

The SysML based Task Analysis / Use Cases supports a methodology to consider workload within the system design, based on the sequential UCs and the consideration of task switching to ensure that scenarios that are recognised to increase workload have their UC initiation simplified.

References

- Dobbins, T. D., Meeks, R., Hespley, M., Howe, H. and Garland, K. (2021). Task Analysis Within The System Model – The Single Source Of Truth. Conference Proceedings; Contemporary Ergonomics & Human Factors 2022. Eds: Golightly, D and Balfe, N. ISBN: 978-1-9996527-4-6.
- Hutton, R.J.B., Nixon, J. and Turner, N.J. (2019) TIN 2.115 – Improving Operator Performance During Exposure to Stressful Environments: Understanding the Impact of Multitasking. Technical Report – Case Studies. OS-DHCSTC_I2_H_T2_115/005.